

FUNCTIONAL VOCATIONAL TRAINING & RESEARCH SOCIETY, BENGALURU



AND



BELLARY DIOCESE DEVELOPMENT SOCIETY, BALLARI



electrician trade curriculum



| jimmy mathew



Curriculum
of
ELECTRICIAN TRADE

Prepared by :
BELLARY DIOCESE DEVELOPMENT SOCIETY
Cantonment, BALLARI

Supported by:
FVTRS, BANGALORE

CHAPTER-1

A. Basic Tools :

1. Combination Pliers



2. Screw Driver Set



3. Tester



4. Nose Plier



5. Electric Knife



B. Measuring Tools :

1. Measuring Tape

High measuring tool



2. Analog Meter



3. Digital Meter



4. Wire Gauge



5. Try Square

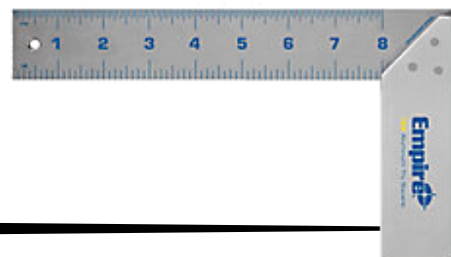

C. Cutting and Chasing Tools :

1. Hand Saw
2. Knife
3. Drilling Tools
4. Chisels



D. Power Tools :

1. Drilling Machine
2. Cutting Machine
3. Demolition Machine
4. Chasing Machine



E. Testing Tools :

1. Test Lamp
2. Digital Multi Meter
3. Clamp Meter
4. Line Tester (500Vn)



Chapter-2

A. Safety Precaution :

- Care full handling of electrical Appliances, using Insulated Hand tools, using current rating fuses effecter earthling.
- Metallic parts using hand glues using rubber mat

B. Causes of Electric Shocks :

- Carelessness
- Accidental
- Over Confidence
- Natural causes (Thunder, Lightening)

C. Effect of Shock On The Human Body :

- On the Brain
- Body
- Kidney

D. Depends On Shock :

- Duration of Current flow
- Amount of Current
- Path of Flow of Current – Location
- Type of Energy and Line Voltage

E. An Electric Shock by Touching :

- Phase and Neutral Touch Equally
- Phase Conductor Standing an Ground
- A Metallic Part when Current is Leaking

F. Causes of Electric Fire and Equipment used to Case Fire :

- Improper Cable for Wiring
- Short Circuit
- Over Loading The Equipment
- Poor Insulation
- Lightening

G. Classification of Fire :

- Solid Fires – Wood, Cloth, Paper
- Liquid Fires – Petrol, Fuel
- Gas Fires – LPG, Gas
- Electrical Fires – Electrical Starts

H. Types of Fire Extinguishers :

- Soda Acid
- Foam Type
- CO₂ Gas
- Dry Chemical Powder
- ABC Powder

FIRE EXTINGUISHER COLOUR CODE

Water	Dry powder	Foam	CO ₂ Carbon dioxide	Vapourising liquids	Wet chemical
For use on Wood, Paper, Textiles etc.	For use on Wood, Paper, Textiles etc. Flammable liquids Domestic fire	For use on Wood, Paper, Textiles etc. Flammable liquids	For use on Flammable liquids Live electrical equipment	For use on Flammable liquids Live electrical equipment	For use on Wood, Paper, Textiles etc. Cooking oil fires
Do not use on Flammable liquids Live electrical equipment	Do not use on Flammable liquids Live electrical equipment	Do not use on Live electrical equipment	Do not use in a confined space		

I. Earthing and Its Method :

1. What is Earthing?

- A wire coming from the ground 2.5cm to 3m deep from an electrode Is called Earthing connected to the main switch board to avoid shocks

2. What are the uses of Earthing?

- To save Human life from Danger / Shock
- To Protect large building and Towers from Lightning
- To Protect machines
- To Maintain the Line Voltage

3. What are the Types of Earthing?

- Pipe Earthing &
- Plate Earthing

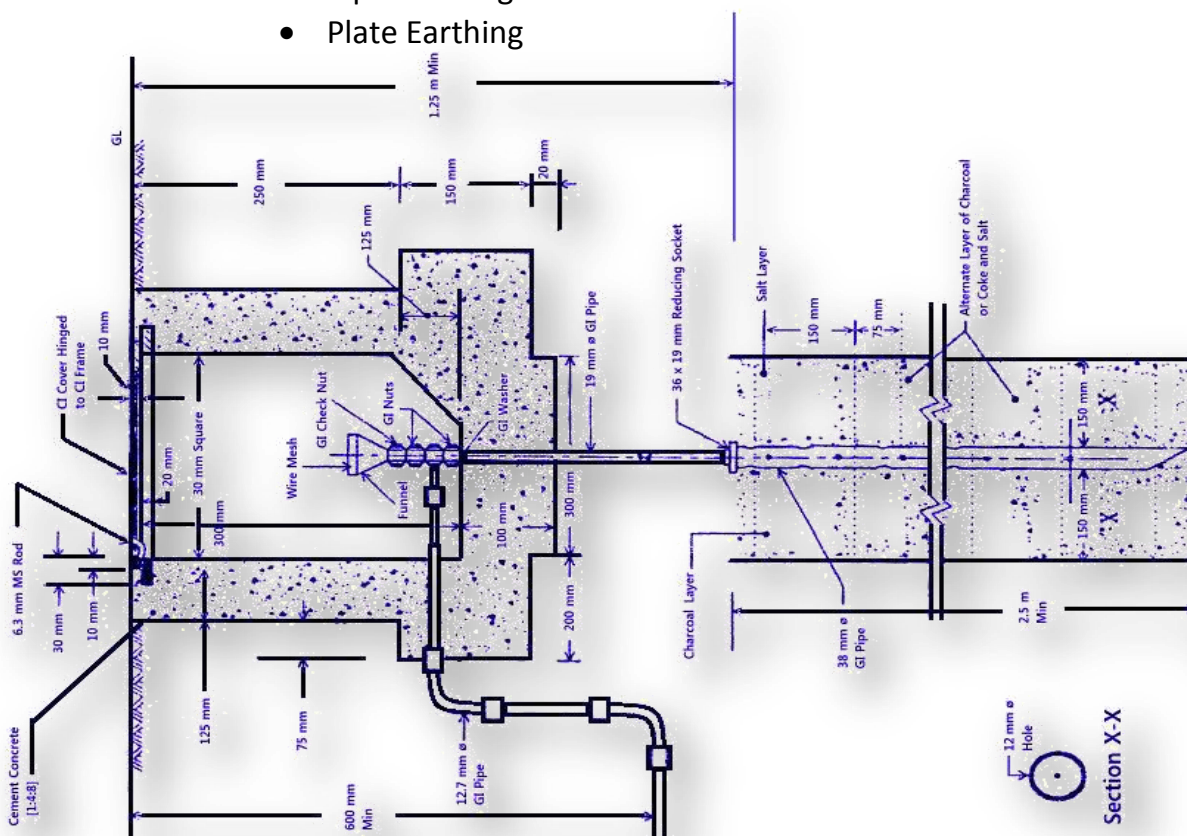

Pipe Earthing

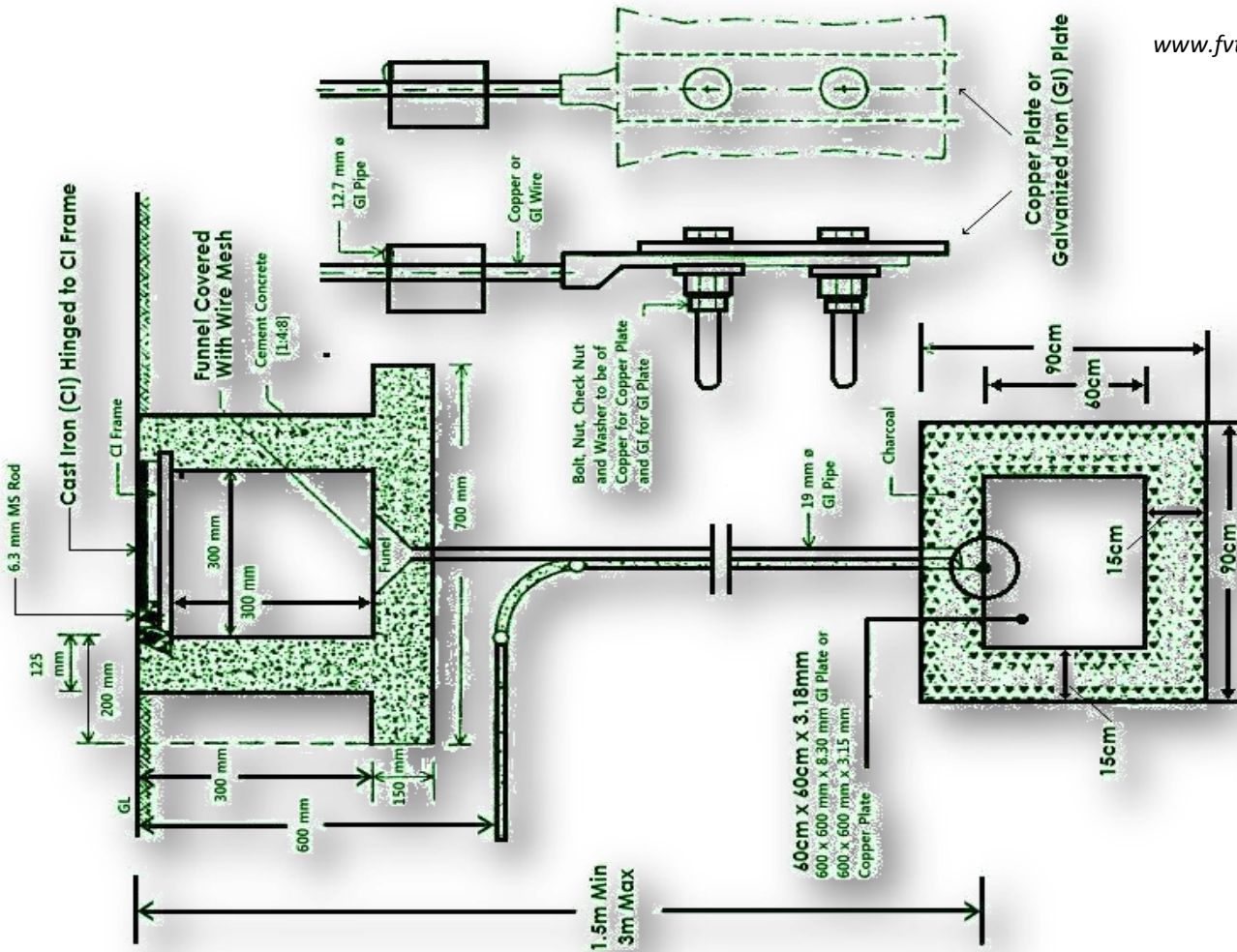

Plate Earthing

Chapter-3

Work, Power & Energy

- Work: When Force applied on a Body Moves in a Direction of Force is called Work.

Formula: Work = Force x Distance

$$W = F \times D$$

Unit of Work: Joule

- Power : Rate of Doing Work is called Power

Formula: $P = W/T$ (W=Work Done, T=Time)

$$P = \frac{F \times D}{T}$$

Power / Force / Distance / Time

- Unit of Power: Joules / Per Seconds
1kilo watt = 1000, watt
1H.P (Horse Power) = 746 watts
- Energy: Energy is a Capacity of Doing Work.

Chapter-4

OHMS "LAW"

1. What is Ohms Law?

- Ohms Law State that Voltage is Directly Proportional to the Current

2. Write the Formula of Ohms Law?

V
I R

$$V = I \times R$$

$$I = V/R$$

Ohm's Law

$$I = \frac{V}{R}$$

Electric current = Voltage / Resistance

$I = V/R$ (current)

$V = IR$ (voltage)

$R = V/I$ (resistance)

3. Types of Circuit

- Open Circuit
- Close Circuit
- Short Circuit
- Leakage Circuit

Closed circuit

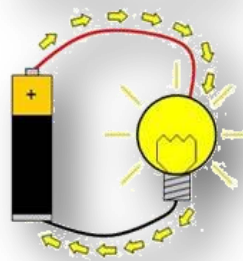

Open circuit

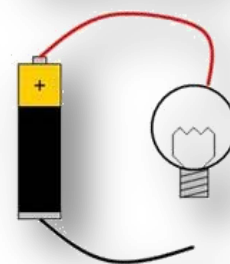

Short circuit

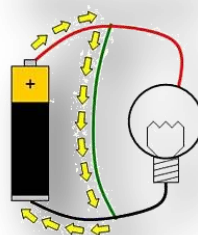

4. What is the Difference between Series and parallel Connection?

• Series Connection

1. Current is same Constant
2. Voltage is Divided
3. Fault Identification is difficult
4. Used for decoration per Pose
5. $V = V_1 + V_2 + V_3$

Parallel Connection

1. Current is Variation
2. Voltage is same Constant
3. Fault Identification Easy
4. Used for Domestic per Pose
5. $1/V = 1/V_1 + 1/V_2 + 1/V_3$

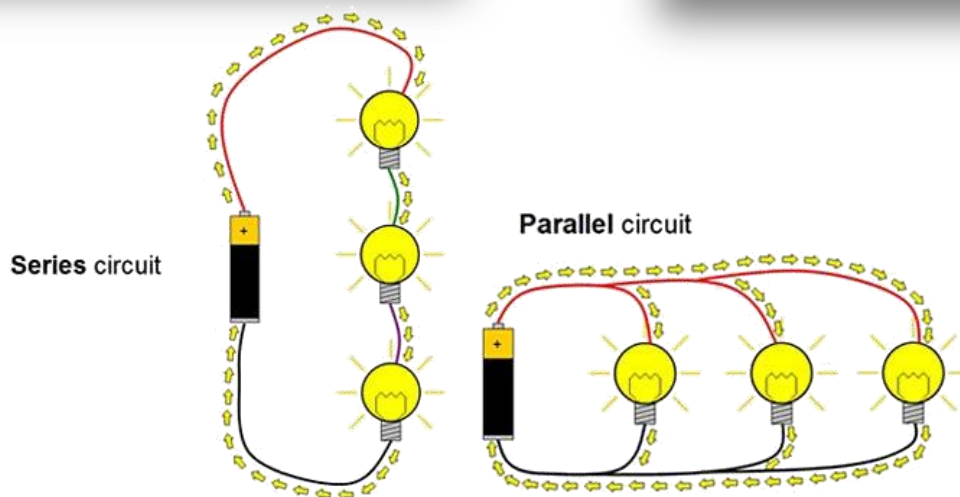
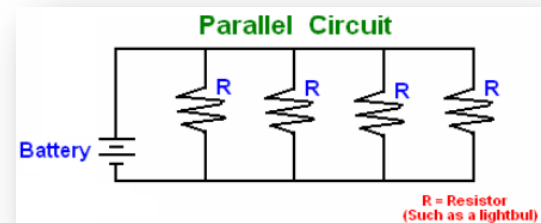
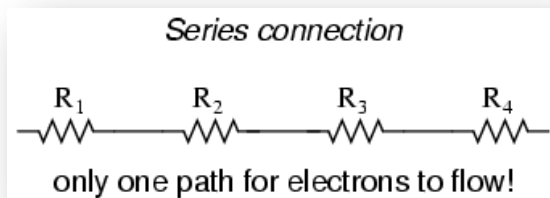

Chapter-5

Conductors and Insulator

1. What is Conductor? Give Example

- It allows the Electric Current is called Conductor EX: Iron, Copper, Silver

2. What is Insulator? Give Example

- It does not allow the Electric Current is called Insulator EX: Paper, Wood, Glass, Plastic, Fiber, and Cotton Etc.

3. What is the Common Conductor used for Electrical Purpose?

- Silver , Copper, Bronze, Brass, Aluminum, Lead, Tin, Carbon, Tungsten

4. What is the Common Insulation used for Electrical Purpose?

- Bakelite, Rubber, Glass, PVC, Porcelain, Fiber, Wood, Oil, Vanish, Cotton tape, Mica

5. What is the Cables According to the Insulator?

- VIR Wires (vulcanize Indian Rubber)
- PVC Wires (Poly Venial Chloride)
- Flexible Wires
- Enameled Wires
- Cotton Covered Wires

❖ Under Ground Cable :

1. Serving
2. Armoring
3. Bedding
4. Lead Sheath
5. Conducting belt
6. Paper Insulation
7. Metallic Screen

❖ Types of Cables :

1. L.T (Low Tension Cable) – Up to 1000V
2. H.T (High Tension Cable) – Up to 11000V
3. S.T (Super Tension Cable) – Up to 33 KV
4. E.H.T (Extra High Tension Cable) – Up to 132 KV

Chapter-6

ELECTRICAL ACCESSORIES

Protecting Device

- | | |
|--|------------------|
| ➤ MCB (Miniature Circuit Breaker) | - 1am to 40am |
| ➤ Fuse | - 6am to 200am |
| ➤ ICDP (Iron Clad Double Pole) | - 32am to 200am |
| ➤ ICTP (Iron Clad Triple Pole) | - 32am to 200am |
| ➤ MCCB (Moulded case Circuit Breaker) | - 100am to 500am |
| ➤ Insulator | - 32am to 63am |
| ➤ FLCB (Earth Leakage Circuit Breaker) | - 40am to 63am |



MCB



FUSE

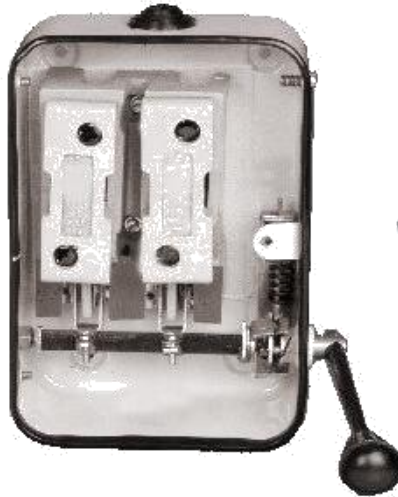

ICDP



ICTP



MCCB



INSULATOR

1. What are the types of Wiring?

- Concealed Wiring (Casing Wiring)
- Conduit Wiring (Open Wiring)
- Wooden Casing and Copping Wiring
- Cleat Wiring

2. Switches :

- According to the rating : 6A, 10A, 16A
- According to the Connection : One way, Two Way

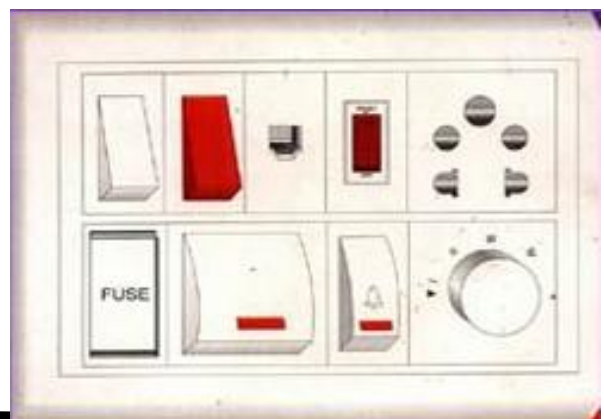

3. Socket :

- According to the rating : 6A, 10A, 16A, 25A
- According to the Connection : 2Pin, 3Pin, 5Pin & Multi Pin

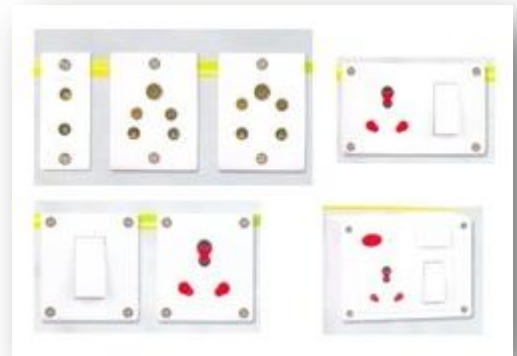

4. Ceiling Roses

Angles & Adaptors:

- Angle Holder
- Batten Holder



- Pendant Holder



- Screw Type / pin Type Holder



5. Sensor Switches :

- Level Sensor (Water level, Oil level)
- Temperature Sensor
- Sound Sensor

- Vibration Sensor
- Dark Sensor



LEVEL SENSOR



SOUND SENSOR



VIBRATION SENSOR

6. What is a Sensor?

- It is a Electronic Circuit, It Works on Sensor Signal

7. Standby Power Sources :

- Generator (Alternator)
- UPS (Uninterrupted Power Supply)
- Inverter



GENERATOR



UPS



INVERTER

Chapter-7

WIRING SYSTEM

1. Customer Expectation :

- Reduction in Electricity Bills
- Safety Against Fire Hazards

- Good Earthing to avoid Electric Shock
- Proper Concealable Wiring

2. How to Provides Customer (Comfort & Supply) :

- Adequate Number of Points (Comfort and Safety)
- Circuitry Design
- ISI Mark Wires
- Higher Cross Sectional Area of Wire
- Earthing With Copper Wire

3. Common Factors Considered in house wiring :

- Cable Selection for Current rating
- Over Loading
- Circuit Design
- Earthing

4. Conduit Wiring uses :

- Godown Wiring
- Cinema Hall
- Work Shop

5. Canceled Wiring :

- House Wiring
- Industrial Wiring
- Software Layout

6. Advantage and Disadvantages of Conduct Wiring and Canceled Wiring

Conduct wiring uses: Advantages:-

- Expenses cost is low
- Fault Identification is easy
- The circuit Design can be change any time

Concealed wiring Advantages:

- It should be seen very clean and neat

Conduct wiring disadvantages:

- It should not be seen neatly
- Damages of pipes and wires

Concealed wiring Disadvantages:

- Fault identification is difficult
- Initial cost is high

Precautions:

- The earth wire should be run within
- The water and gas should be away from
- The conduit pipes should be cut properly
- House wiring system should be used while

Different conductors used for house wiring according to the core

- Single core wire
- Two core wire
- Three core wire
- Four core wire

According to the insulation

- VIR wire
- CTS wire (Cable sheathed)
- PVC wire
- Weather proof wire
- Enameled wire
- Fire Resisting

According to the metal

- Bare copper
- ACSR Conductor
- Fuse wire
- Nichrome wire

Color code of electrical wiring system

1 \emptyset Ac Supply :- Red for phase
 Black for Neutral
 Green for earthing

3 \emptyset Ac Supply :- **R → Red**
 Y → Yellow
 B → Blue

Long forms of electrical equipments

1. PVC : Polyvinyl chloride
2. MCB: Miniature circuit breaker
3. MCCB: Modulated case circuit Breaker
4. MPCB: Modulated protective circuit breaker
5. ICDP: Iron clance double pole
6. ICTP: Iron cland trible pole
7. ELCB: Earth leakage circuit breaker
8. OLR: Over load relay
9. MPR: Motor protection relay
10. ER: Economic relay
11. BR: Timer relay
12. BR: Breaker relay
13. EMF: Electro Motive force
14. DOL: Direct online
15. UPS: Uninterrupted power supply
16. RPM : Revolutionperminute
17. OHL : Over Head line
18. UGL: Underground cable
19. SWG: Standard wire guage
20. HRC: High Repchuring capacity
21. KVC: Kilo voltas Ampere
22. VIG: Voltage

- 23. EOT: Electrical over head travelling
- 24. Time choke is used to maintain the constant V/g
- 25. AVR: Automotive voltage regulate control
- 26. LED: Light Emitting diode

ELECTRICAL SYMBOLS

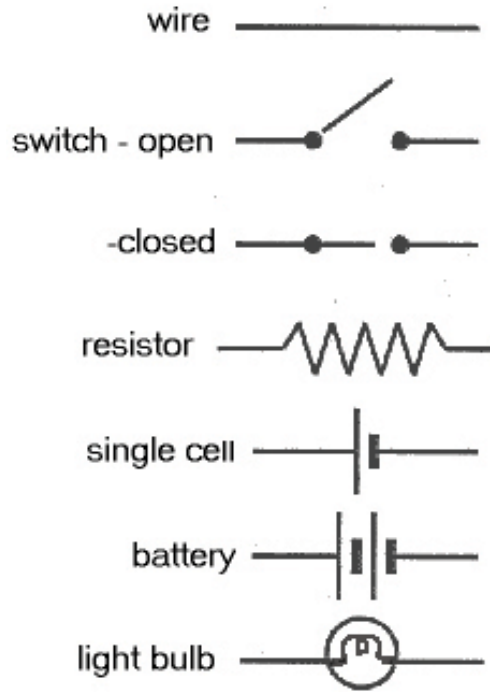

Fuse 

Single pole circuit breaker 

2 pole circuit breaker 

Disconnect switch 

3 pole 1 throw switch 

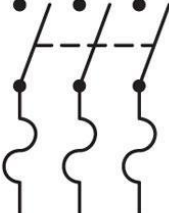
3 pole 1 throw fused switch 

Earth ground 

Chassis ground 

Inverter 

Current transformer 

Transformer 

PV module 

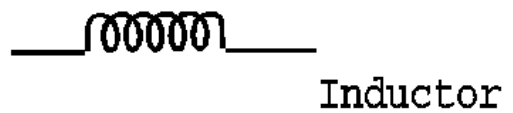
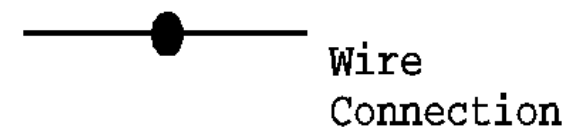
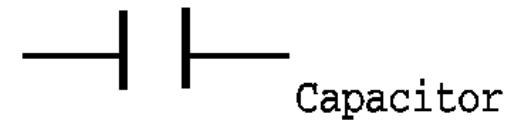
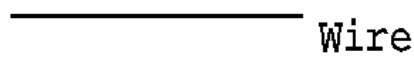
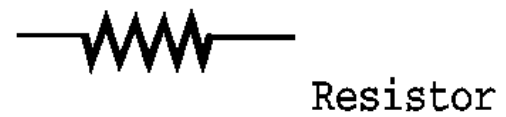
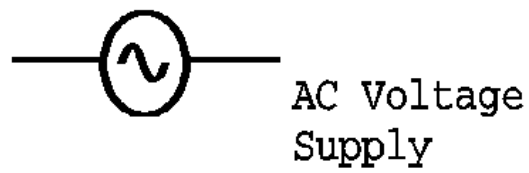
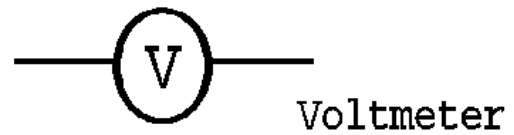
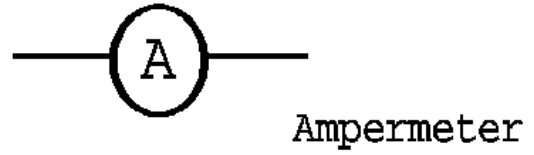
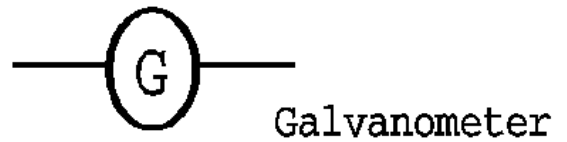
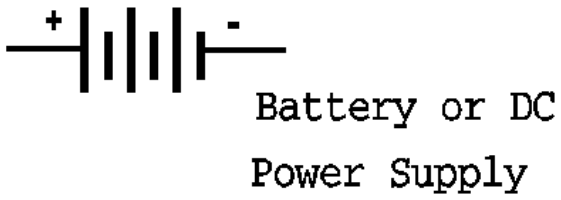

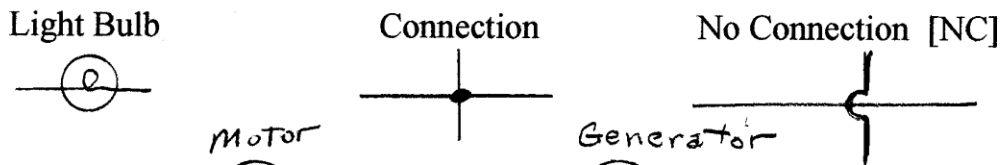
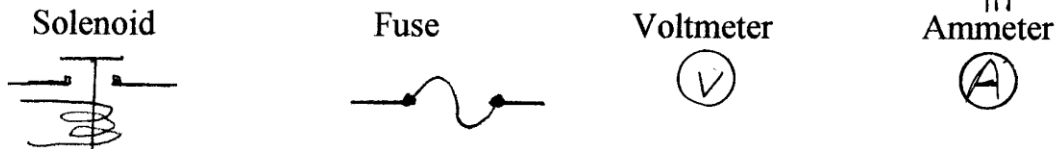
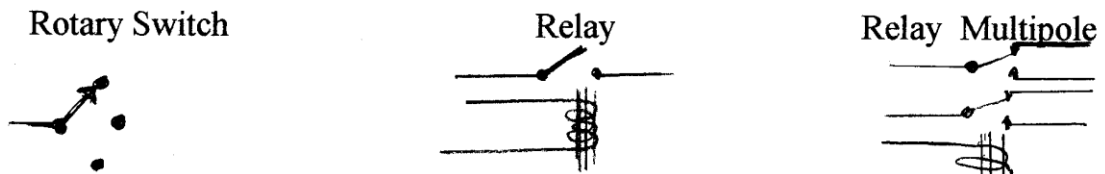
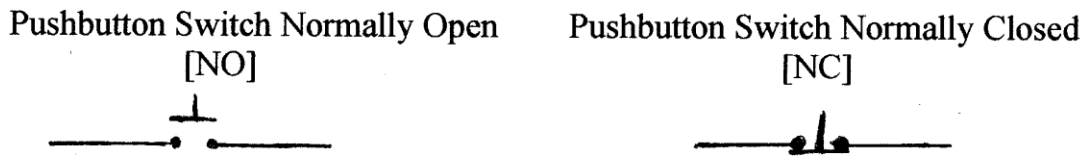
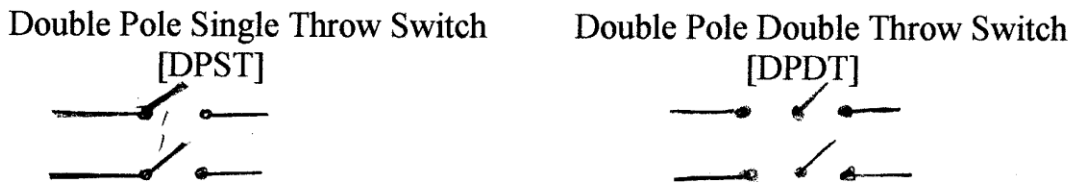
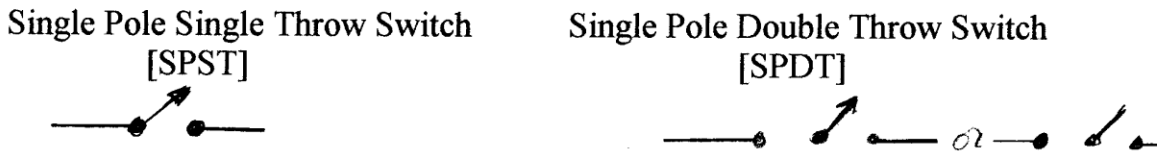
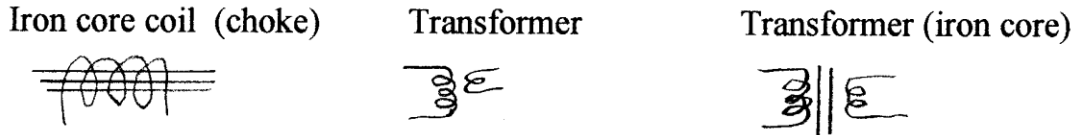
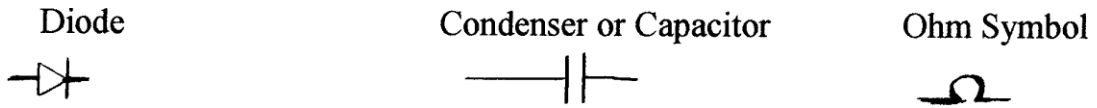

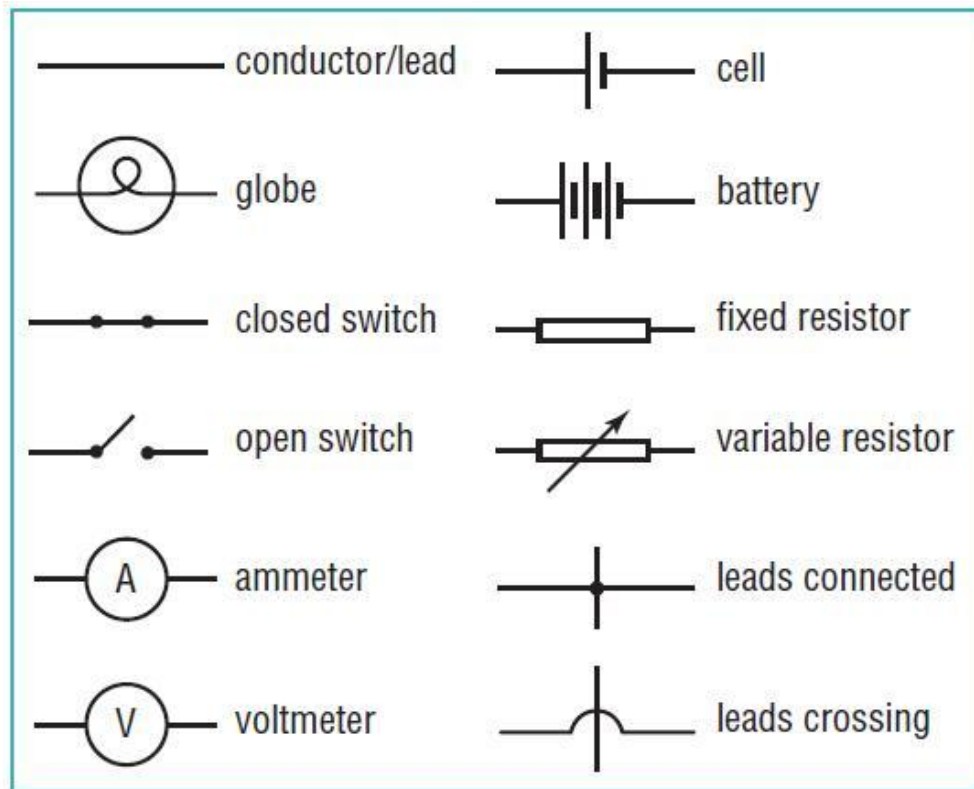

Electrical symbols

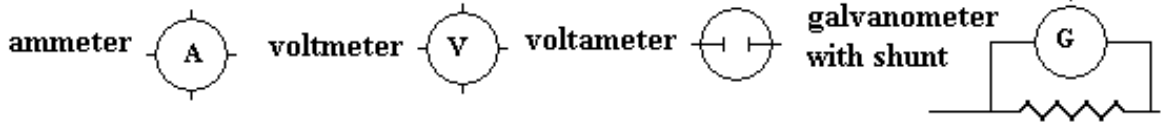
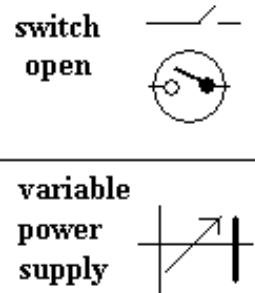
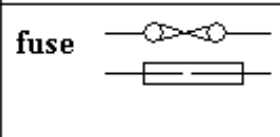
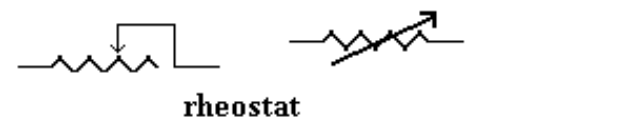
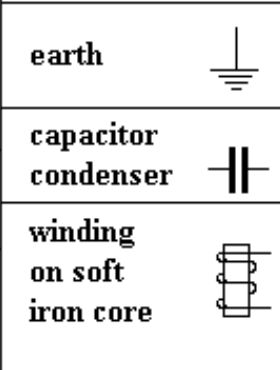
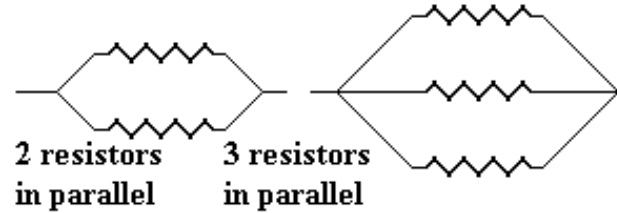
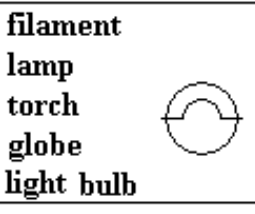
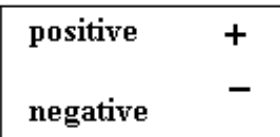
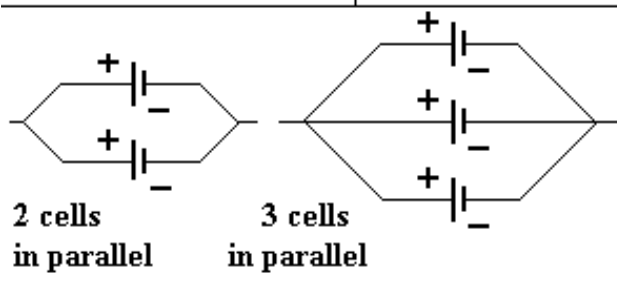
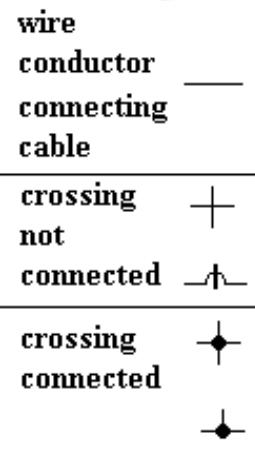
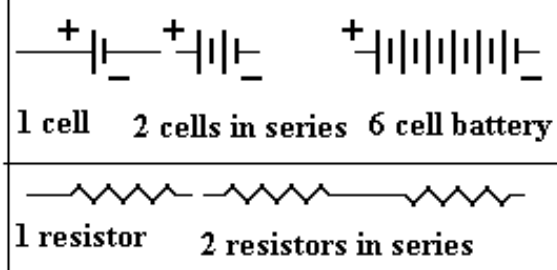
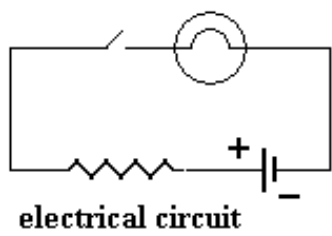

Chapter – 8

PRINCIPLES OF ELECTRICITY

1 what is electricity?

Electricity is an intangible form of energy but it can be felt through its effects.

2 What is current?

Current is a flow of free electrons through a conductor called current. The SI unit for measuring an electric current is the ampere, which is the flow of electric charge across a surface at the rate of one coulomb per second. Electric current is measured using a device called an ammeter.

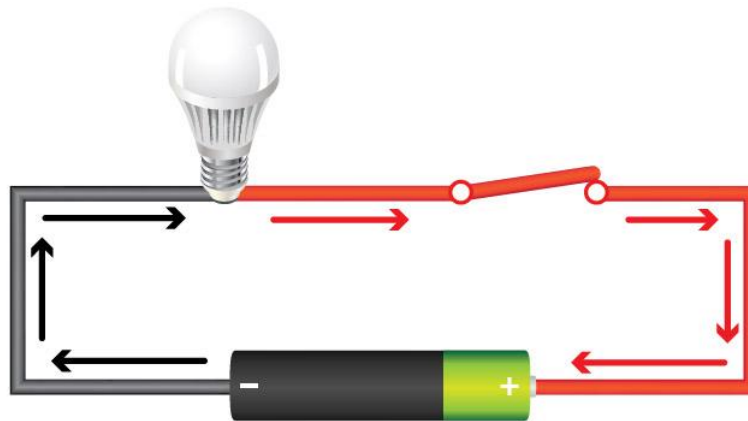

3 What is a voltage?

Voltage is the pressure from an electrical circuit's power source that pushes charged electrons (current) through a conducting loop, enabling them to do work such as illuminating a light. In brief, **voltage = pressure**, and it is measured in volts (V). Voltage is represented in equations and schematics by the letter "V".

- Voltage is measured in the units of '**volts**'.

4 what is resistance?

When electrons flow through a bulb or another conductor, the conductor offers some obstruction to the current. This obstruction is called electrical resistance.

- The longer the conductor, the higher the resistance.
- The smaller its area, the higher its resistance.

Every material has an electrical resistance and it is the reason that the conductor give out heat when the current passes through it.

Resistance measure in ohm resistance unit is ohm's

Resistance symbol is Ω

Effect of electric current:



Heating: The heating effect of electric current is used in many everyday devices. Electric cookers, kettles and toasters are among the household appliances that rely on it.

Joule's Law states that the rate at which heat is produced in a resistor is proportional to the square of the current flowing through it, if the resistance is constant.

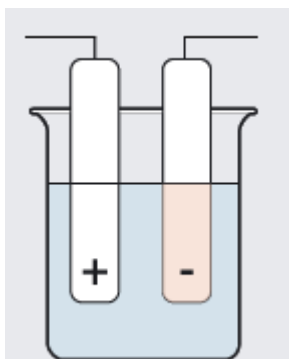

Chemical: Passing an electric current through a liquid causes chemical changes in a process called electrolysis.

Electroplating uses electrolysis to put a layer of one metal on top of another. Examples include chromium plating of bathroom and car parts, and silver plating of cutlery and jewellery.

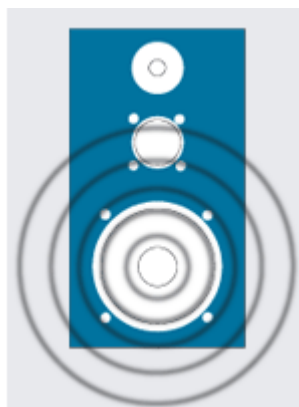

Magnetic: Electric current passing through a wire generates a magnetic field around the wire.

This effect is used in all sorts of ways. Examples include electric motors and electromagnets. In a car, for example, the central locking uses electromagnets called solenoids to operate the lock mechanism.

Another widespread example is the loudspeaker, where variations in the magnetic effect of an electric current are translated into sound waves that we can hear.

Instrument	Unit	Symbol
Current	Amper	I
Voltage	Volt	V
Resistance	Ohm's	Ω
Power	Watts Joules	w
Frequency	Hertz	H2

Chapter – 9

MOTOR

Types of Motor:

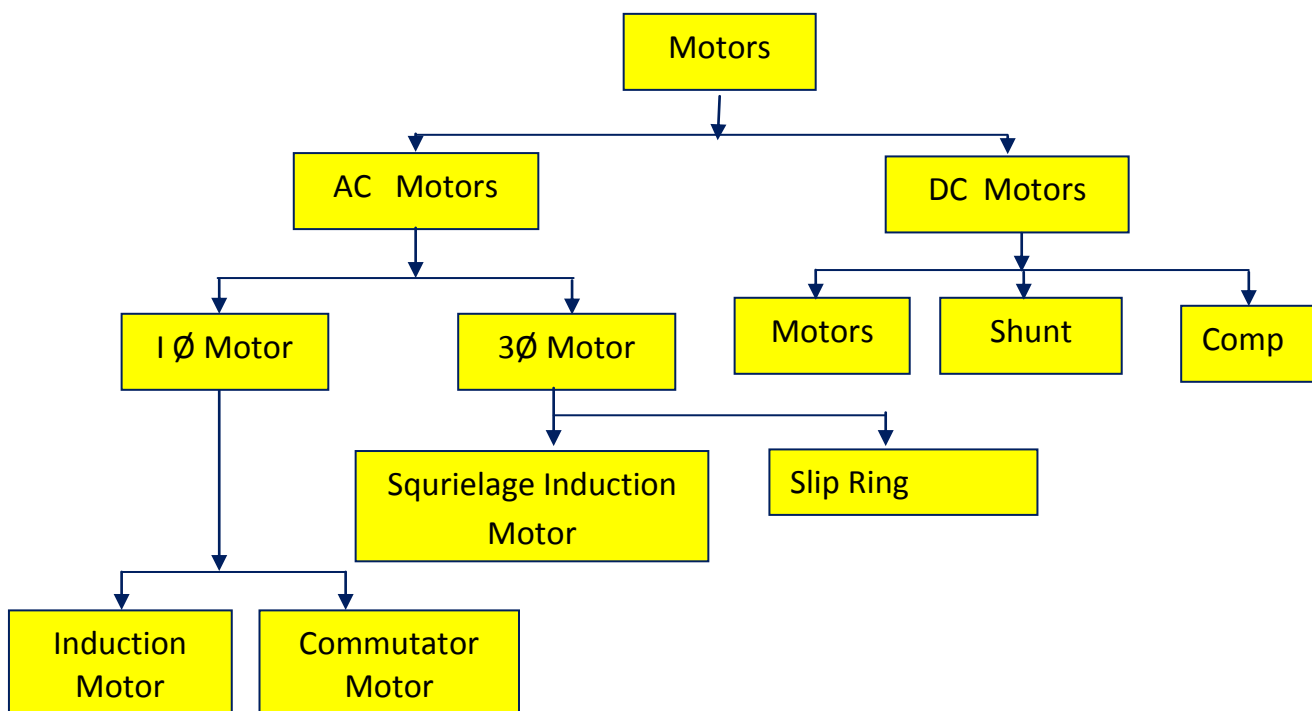

1. What is Motor

Motor is a device which converts electricity into mechanical energy

2. Where the motor are used?

Residential (home)
Commercial (Agriculture)
Industrial (IO)

Characters of a Motor:-

- Starting current is high
- Starting torque is low with increase with
- Constant speed but slowly increases in load
- Power factor is low
- Maintenance cost is low

DIRECT-CURRENT MOTORS - DC motors are divided into three classes, designated according to the method of connecting the armature and the field windings as shunt-series and compound wound.

SHUNT-WOUND MOTORS - This type of motor runs practically constant speed, regardless of the load. It is the type generally used in commercial practice and is usually recommended where starting conditions are not usually severe. Speed of the shunt-wound motors may be regulated in two ways: first, by inserting resistance in series with the armature, thus decreasing speed: and second, by inserting resistance in the field circuit, the speed will vary with each change in load: in the latter, the speed is practically constant for any setting of the controller. This latter is the most generally used for adjustable-speed service, as in the case of machine tools.

SERIES-WOUND DC MOTORS - This type of motor speed varies automatically with the load, increasing as the load decreases. Use of series motor is generally limited to case where a heavy power demand is necessary to bring the machine up to speed, as in the case of certain elevator and hoist installations, for steelcars, etc. Series-wound motors should never be used where the motor can be started without load, since they will race to a dangerous degree.

COMPOUND-WOUND DC MOTORS - A combination of the shunt wound and series wound types combines the characteristics of both. Characteristics may be varied by varying the combination of the two windings. These motors are generally used where severe starting conditions are met and constant speed is required at the same time.

SQUIRREL-CAGE INDUCTION MOTORS - The most simple and reliable of all electric motors. Essentially a constant speed machine, which is adaptable for users under all but the most severe starting conditions. Requires little attention as there are no commutator or slip-rings, yet operates with good efficiency. Squirrel cage motors are common in many household appliances including washing machines, Miele dishwashers, and stand alone fans.

WOUND-ROTOR (SLIP RING) INDUCTION MOTOR - Used for constant speed-service requiring a heavier starting torque than is obtainable with squirrel cage type. Because of its lower starting current, this type is frequently used instead of the squirrel-cage type in larger sizes. These motors are also used for varying-speed-service. Speed varies with this load, so that they should not be used where constant speed at each adjustment is required, as for machine tools.

Single Phase Induction Motors - This motor is used mostly in small sizes, where polyphase current is not available. Characteristics are not as good as the polyphase motor and for size larger than 10 HP, the line

What are the parts or motor?

- Stator : it is stationary part
- Rator: it is Roating part
- Bearing:
- Eam:
- End cover
- Eye bolt

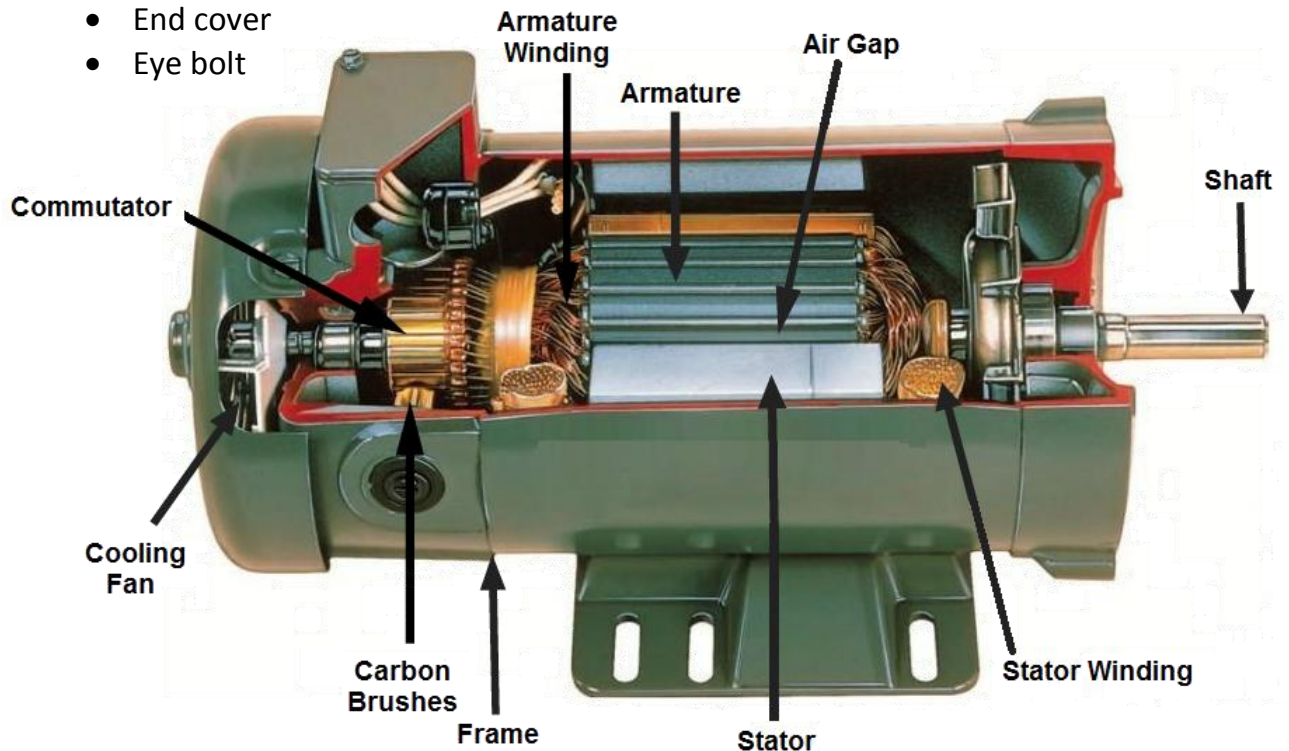

Basic Parts of the Motor

Working principle of induction motor?

3 phase AC current passing through a Stator winding produces a rotating magnetic field. The current will be induced in the bars of the squirrel cage and it will start to rotate. The induced current in squirrel cage bars. This is due to the rate of change of magnetic flux in one squirrel bar pair which is different from another, due to its different orientation. This variation of current in the bar will change over time.

That's why the name induction motor is used, electricity is induced in rotor by magnetic induction rather than direct electric connection. To aid such electromagnetic induction, insulated iron core laminated are packed inside the rotor.

Types of Speeds:

- Constant speed
- Variable speed
- Adjustable speed (RPM) Revolution per minute

Reason of motor failure

- Bush out fuse
- Wrong out bearing
- Short circuit
- Loose motor bars
- Wrong connection
- Grounded winding
- Over load

Reason of motor runs slowly:

- Shortened coils
- Reverse coiling
- Wrong out bearing
- Reversed phase
- Overload
- Wrong connection

DC GENERATOR

1. What is an DC Generator?

Generator is a device which convert mechanic energy into electrical energy.

2. What is the working principle of DC Generator

Faraday's law of electromagnetic Induction

3. List the parts of DC Generator

- Yoke
- Brushes and bearing
- Armature
- Commutator
- Bushes and bearing
- Field coils
- Pole core and pole shoe

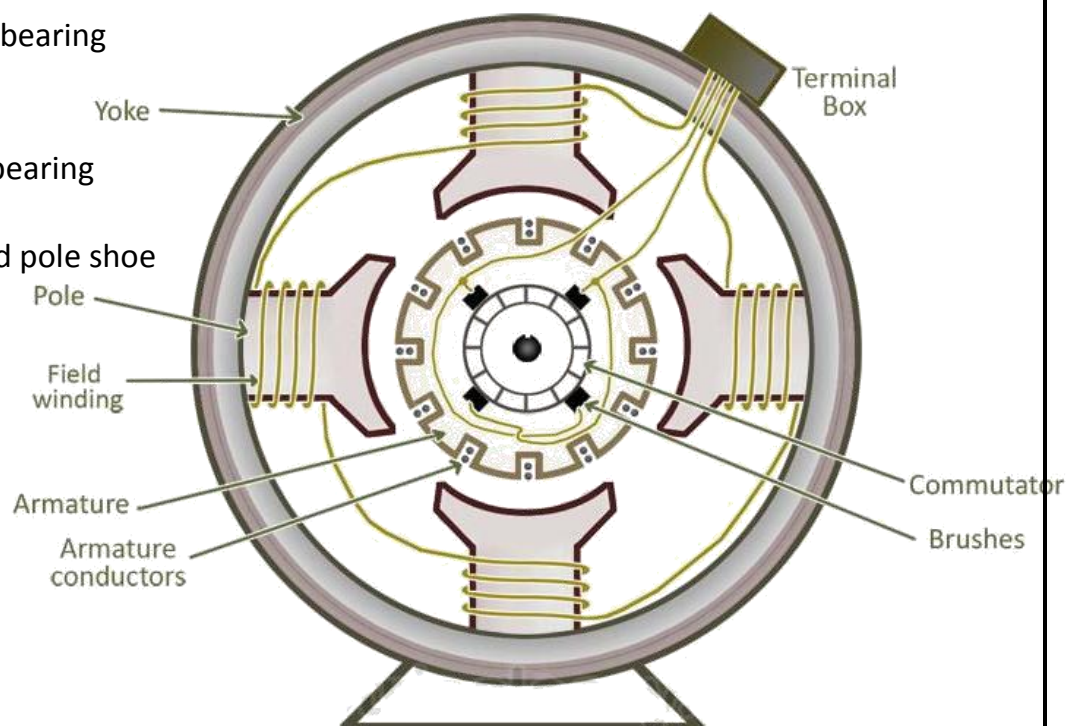

List the types of self excited generator

- Self excited generator
- Separately excited generator

List the types of self excited generator?

- Series wound generator
- Shunt wound generator
- Compound wound generator

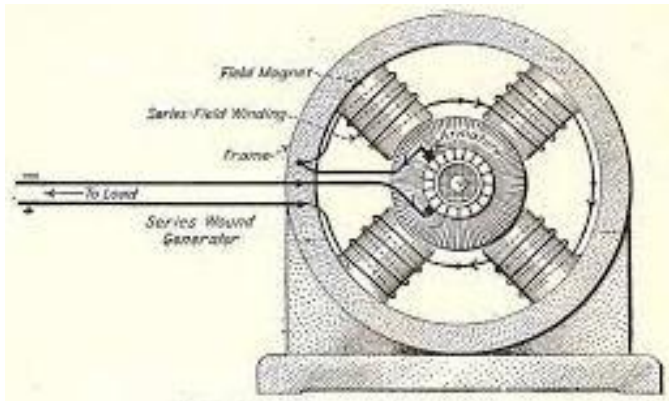

Series wound generator

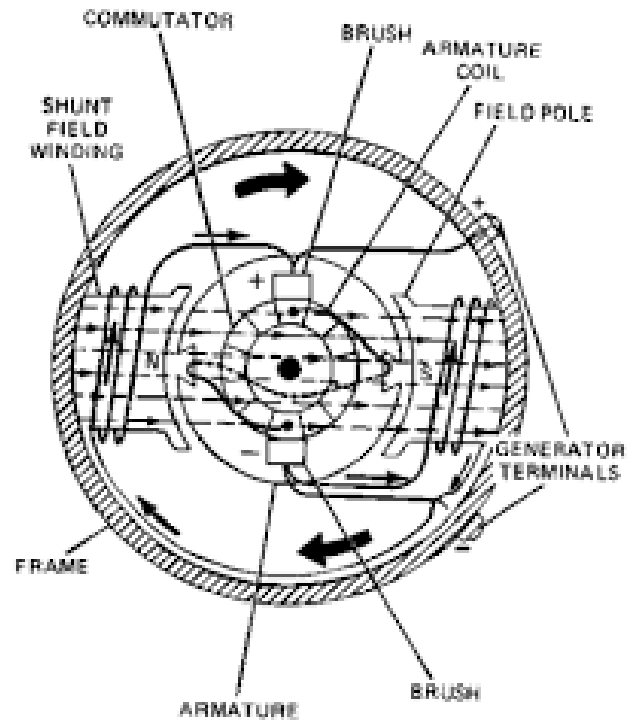

Shunt wound generator

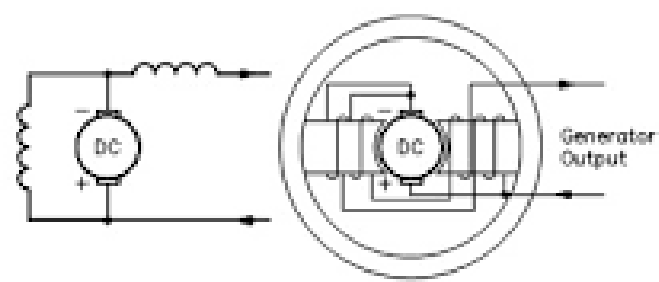
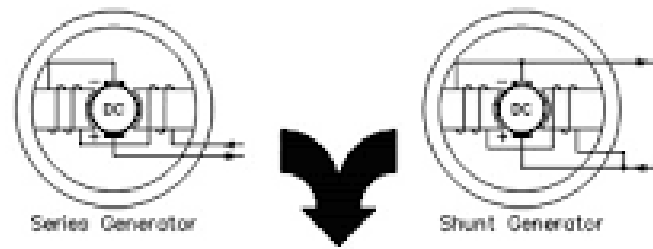

Compound wound generator

STARTERS

1. What is starter?

Starter is a device which helps to start the AC motor to protect the motor from over load and current.

2. List of starters?

DIRECT – ON LINE STARTER

The simplest form of motor starter for the induction motor is the Direct On Line starter. The DOL starter consist a MCCB or Circuit Breaker, Contactor and an overload relay for protection. Electromagnetic contactor which can be opened by the thermal overload relay under fault conditions.

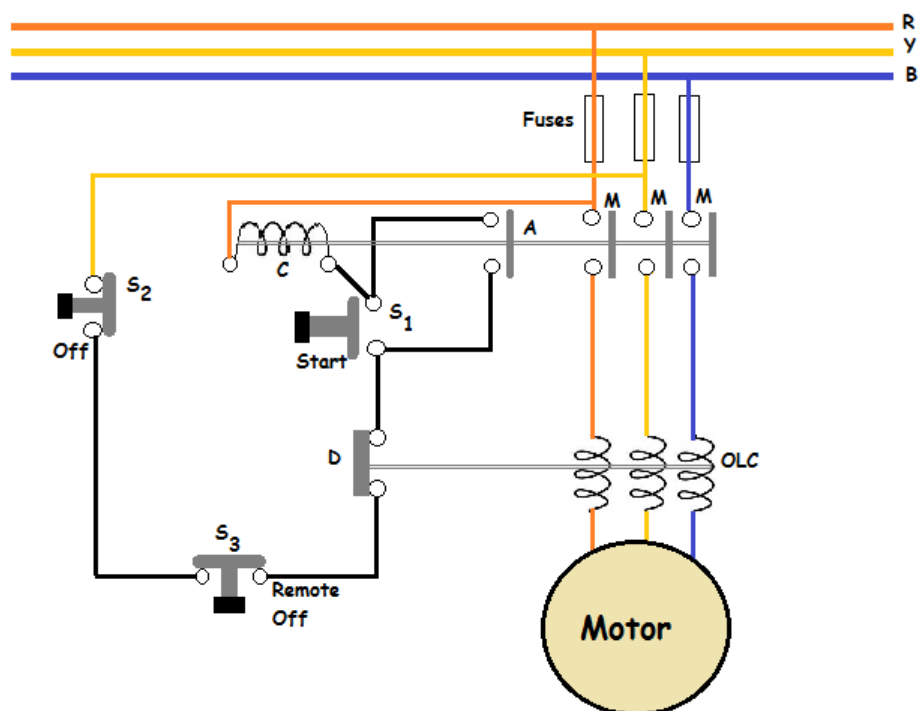

Direct On Line (DOL) Starter Wiring Diagram

Direct: on line (DOL)

Advantage:

- 1) The motor can be switched on and off quickly
- 2) It protect the motor from over load
- 3) It maintains constant voltage

Protective devices:

- 1) No volt Coil (NVC)
- 2) Overload relay (OLR)
- 3) Star delta starter (SDS)
- 4) MCB, MCCB, MPCB, Fuse

Over load relay:

- 1) Over voltage
- 2) Over load
- 3) Motor temperature

Common faults occur if

- the starter connection is wrong
- the starter load relay coil is defective
- the starter slip ring motor is earthed
- the No-volt coil is not functioning

STAR – DELTA STARTER

Star/Delta starters are probably the most common reduced voltage starters. They are used in an attempt to reduce the start current applied to the motor during start as a means of reducing the disturbances and interference on the electrical supply.

The Star/Delta starter is manufactured from three contactors, a timer and a thermal overload. The contactors are smaller than the single contactor used in a Direct on Line starter as they are controlling winding currents only. The currents through the winding are $1/\sqrt{3}$ (58%) of the current in the line.

Star delta starter:

- 1) This starter fitted in 8 to 10 HP motors
- 2) The motor start in start and runs in Delta

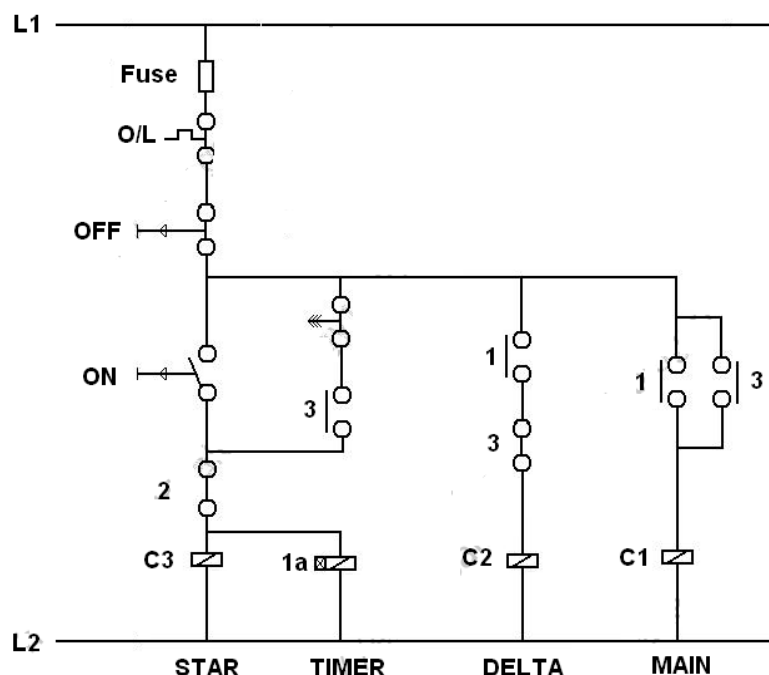

Control Circuit Diagram of Automatic Star Delta (Y-Δ) starter with Timer for 3-Phase Motor.

Chapter - 10

Transformer :

The transformer may be defined as a static piece of electrical apparatus which converts electrical power from one circuit to another at the same frequency while changing the corresponding values of current and voltage.

Principle transformer: The transformer works on the principle of Mutual induction.

Classification of transformer

A. According to the magnetic core

- Core Type
- Shell type
- Berry Type

B. According to the voltage

- Step Up transformer
- Step Down transformer
- 1:1 transformer

C. According to the phases/Winding

- Single phase
- Three phase

D. According to the power

- Lighting / distribution transformer
- Power transformer

E. According to the cooling

- Self cooled
- Air cooled
- Oil cooled
- Forcibly oil cooled.

F. According to the location

- Indoor transformer
- Outdoor transformer

G. According to the output :

- Auto Transformer
- Instrument transformer

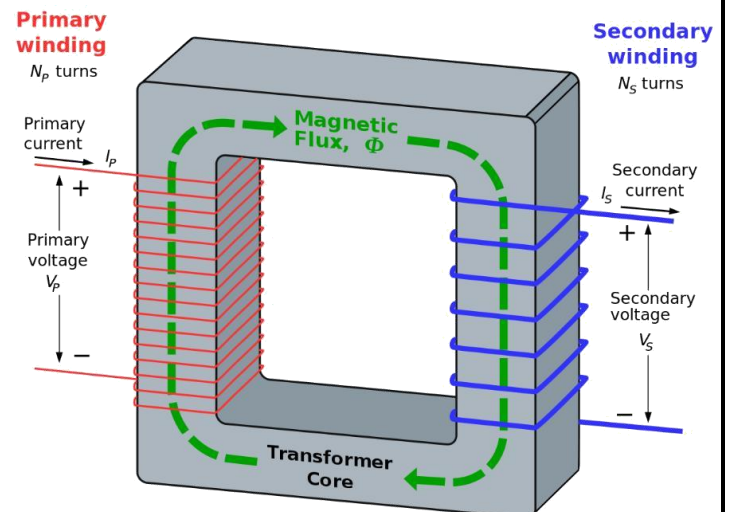

H. List the types of power generator

- Wind power energy



- Solar power energy

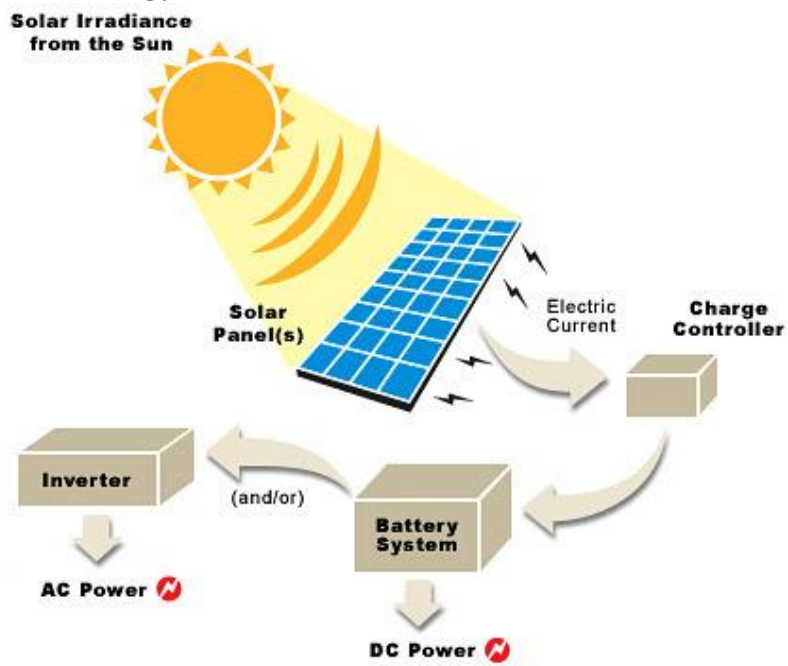

- Thermal power energy

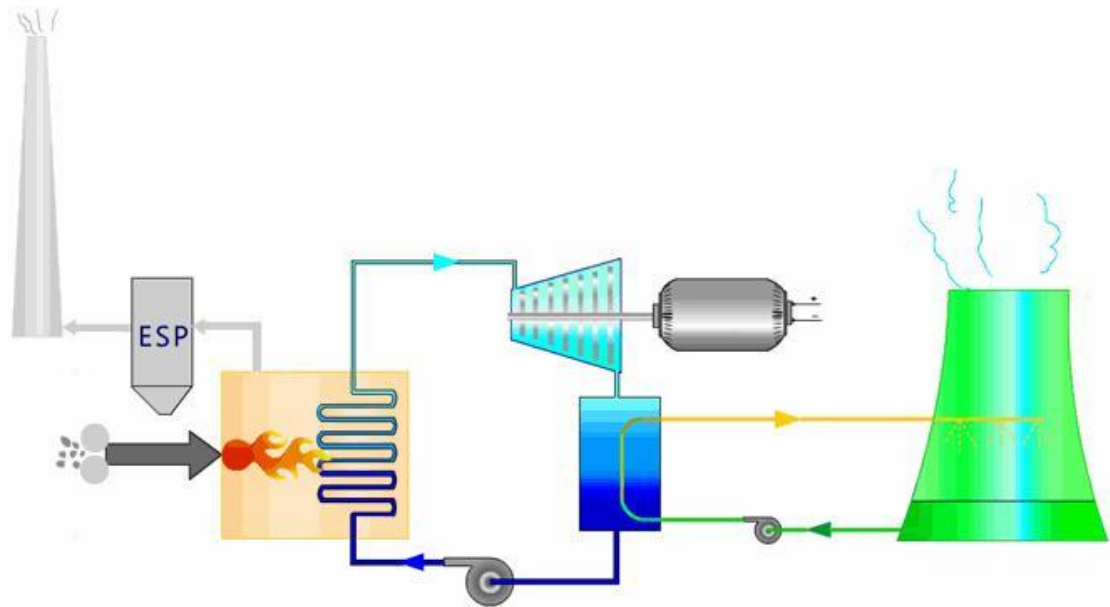

- Hydro power energy

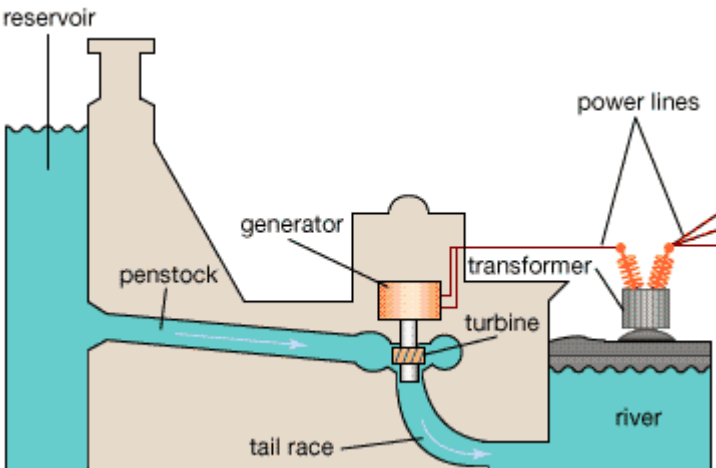

- Nuclear power energy

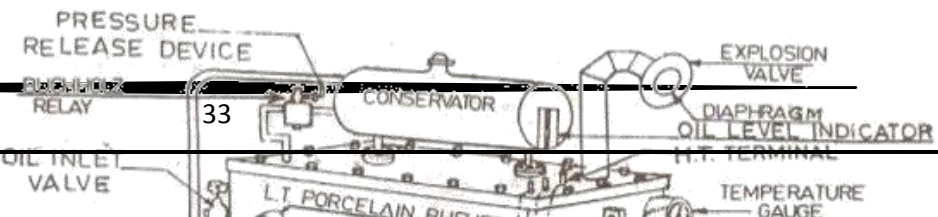
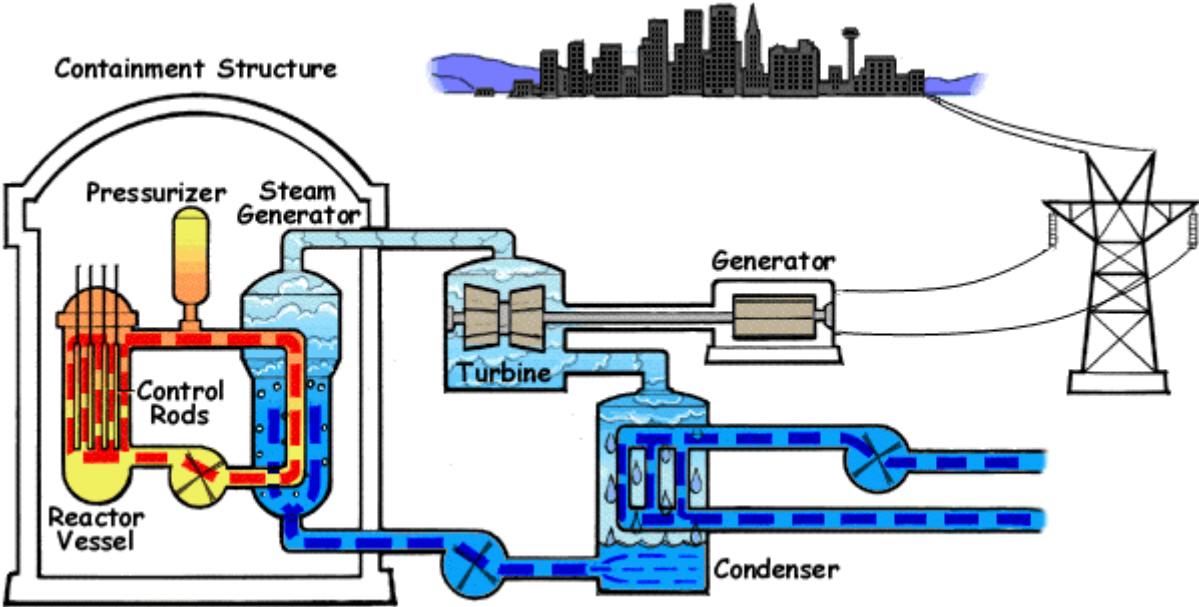

1. Part of transformer?

- Conservator
- Breather
- Temperature
- Oil guage
- Expulsion vent
- Pipes iron
- Buchloz relay
- Primary winding
- Secondary winding

1. **Conservator:** it is a small tank mounted over the top of the transformer it helps to store the oil
2. **Breather:** in breather is filled the silica get it helps to adsorb the massive
3. **Temperature gauge:** it measure the irons fowmers winding temperature.
4. **Oil gauge:** it helps measure the irons former oil level
5. **Bunch loloz's relay:** it protect the transformer winding in case of any short circuit in the transformer winding
6. **Winding:** it is made up of copper it used to improve the power.

1. **Step Up transformer:**As the name specifies the secondary voltage is stepped up with a ratio compared to primary voltage. This is achieved by increasing the number of coil turns in the secondary as shown in figure.

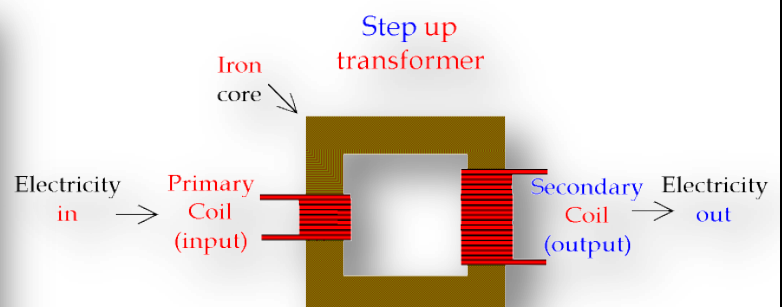
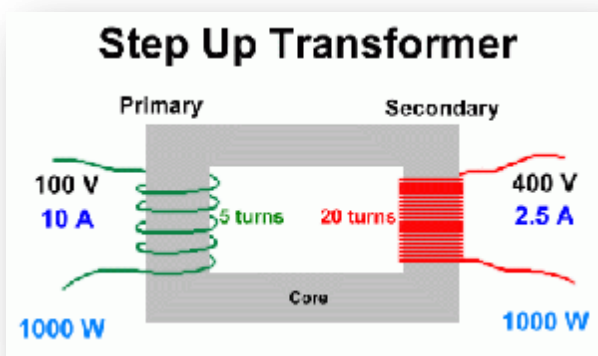

2. **Step down transformer:**In this transformer the voltage is stepped down at the secondary from high voltage primary so that it is called as step-down transformer. The winding turns will be high at primary side where as it will less at secondary side.

Step Down Transformer

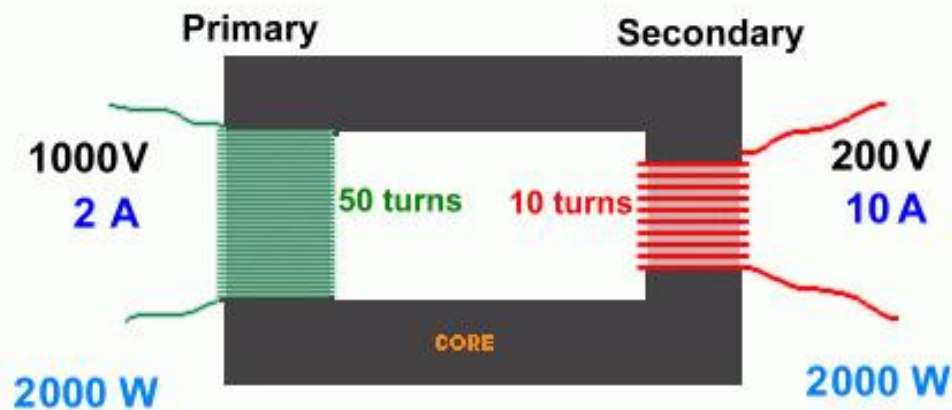

3. **1:1 Transformer:** Transformers that have a ratio of 1 to 1 between the primary and secondary windings are often used to protect secondary circuits and individuals from electrical shocks between energized conductors and earth ground. Suitably designed isolation transformers block interference caused by ground loops. Isolation transformers with electrostatic shields are used for power supplies for sensitive equipment such as computers, medical devices, or laboratory instruments.

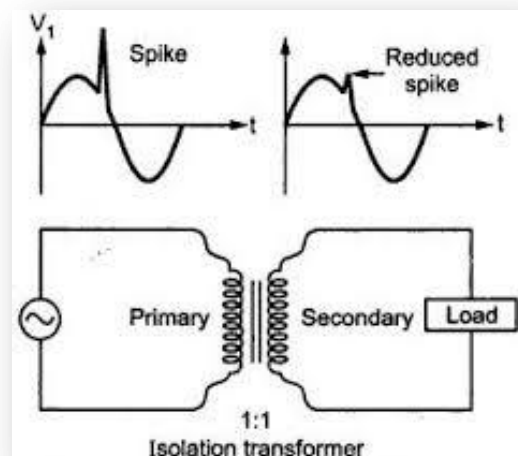
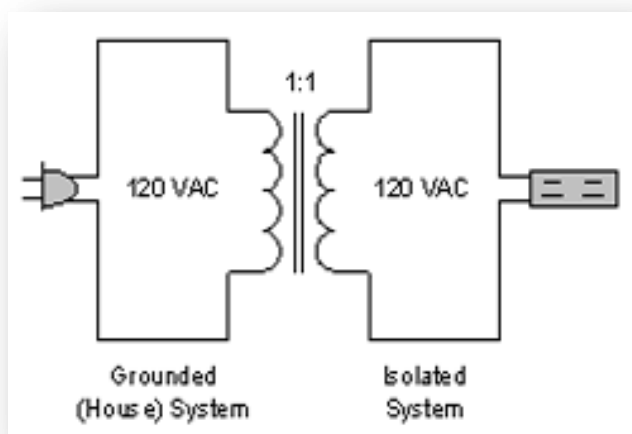

Chapter 11

Uninterrupted power supply (UPS)

An uninterruptible power supply, also uninterruptible powersource, UPS or battery/flywheel backup, is an electrical apparatus that provides emergency power to a load when the input power source, typically mains power, fails. A UPS differs from an auxiliary or emergency power system or standby generator in that it will provide near-instantaneous protection from input power interruptions, by supplying energy stored in batteries, supercapacitors, or flywheels. The on-battery runtime of most uninterruptible power sources is relatively short (only a few minutes) but sufficient to start a standby power source or properly shut down the protected equipment.

A UPS is typically used to protect hardware such as computers, data centers, telecommunication equipment or other electrical equipment where an unexpected power disruption could cause injuries, fatalities, serious business disruption or data loss.

UPS

1. Online UPS:

In an online UPS, the batteries are always connected to the inverter, so that no power transfer switches are necessary. When power loss occurs, the rectifier simply drops out of the circuit and the batteries keep the power steady and unchanged. When power is restored, the rectifier resumes carrying most of the load and begins charging the batteries, though the charging current may be limited to prevent the high-power rectifier from overheating the batteries and boiling off the electrolyte. The main advantage of an on-line UPS is its ability to provide an "electrical firewall" between the incoming utility power and sensitive electronic equipment.



2. Offline UPS :



The offline/standby UPS (SPS) offers only the most basic features, providing surge protection and battery backup. The protected equipment is normally connected directly to incoming utility power. When the incoming voltage falls below or rises above a predetermined level the SPS turns on its internal DC-AC inverter circuitry, which is powered from an internal storage battery. The UPS then mechanically switches the connected equipment on to its DC-AC inverter output.

The switchover time can be as long as 25 milliseconds depending on the amount of time it takes the standby UPS to detect the lost utility voltage. The UPS will be designed to power certain equipment, such as a personal computer, without any objectionable dip or brownout to that device.

Chapeter – 12

DIESEL GENERATOR (DG)

1. Generator:

Generator is a device which covert Mechanicalenergy into electrical energy is called Generator

2. Diesel Generator (DG)

A diesel generator is the combination of a diesel engine with an electric generator (often an alternator) to generate electrical energy. This is a specific case of engine-generator. A diesel compression-ignition engine often is designed to run on fuel oil.

Diesel generating sets are used in places without connection to a power grid, or as emergency power-supply if the grid fails, as well as for more complex applications such as peak-lopping, grid support and export to the power grid.

Sizing of diesel generators is critical to avoid low-load or a shortage of power and is complicated by modern electronics, specifically non-linear loads. In size ranges around 50 MW and above.

3. The faults occur in Diesel Generator.

- Over load
- Over current
- Earth fault
- Undervoltage

4. Engine damage

Diesel engines can suffer damage as a result of misapplication or misuse.

Internal glazing and carbon build-up is due to prolonged periods of running at low speeds or low loads. Such conditions may occur when an engine is left idling as a 'standby'

generating unit, ready to run up when needed, (misuse); if the engine powering the set is over-powered (misapplication) for the load applied to it, causing the diesel unit to be under-loaded, or as is very often the case, when sets are started and run off load as a test (misuse).

Running an engine under low loads causes low cylinder pressures and consequent poor piston ring sealing since this relies on the gas pressure to force them against the oil film on the bores to form the seal. Low cylinder pressures causes poor combustion and resultant low combustion pressures and temperatures.

Hard carbon forms from poor combustion and this is highly abrasive and scrapes the honing marks on the bores leading to bore polishing, which then leads to increased oil consumption (blue smoking) and yet further loss of pressure, since the oil film trapped in the honing marks is intended to maintain the piston seal and pressures.

Under-loaded running inevitably causes not only white smoke from unburnt fuel but over time will be joined by blue smoke of burnt lubricating oil leaking past the damaged piston rings, and black smoke caused by damaged injectors. This pollution is unacceptable to the authorities and neighbors.

5. Type of water is used to cool Diesel Generator

D Minarised water is used to cool Diesel Generator

6. Diesel generator – Its parts

The main components of an Diesel Generator can be broadly classified as :

1. Engine
2. Alternator
3. Fuel system
4. Governor
5. Voltage Regulator
6. Cooling and Exhaust Systems
7. Lubrication system
8. Battery and Battery Charger
9. Control Panel (Automatic Mains Failure panel)
10. Fly wheel

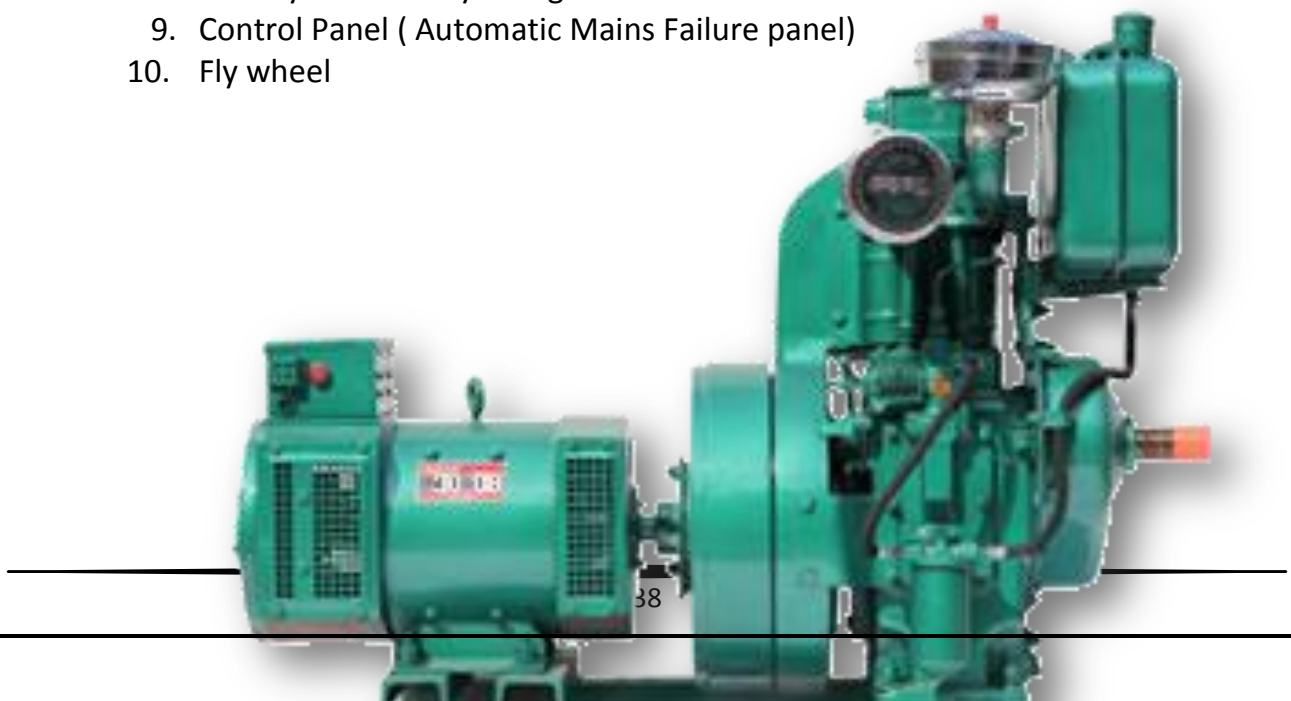

This Curriculum is developed as part of



**OUR HEARTFELT THANKS
TO :**

FVTRS, Bengaluru

for the guidance and financial support

Director and Staff of

Don Bosco Technical School, Hospet

for sharing ideas for developing this Curriculum

and

Director & Staff of BDDS, Ballari

for developing, printing and sharing this Curriculum